

## 335/350/123 Variable area flow meter

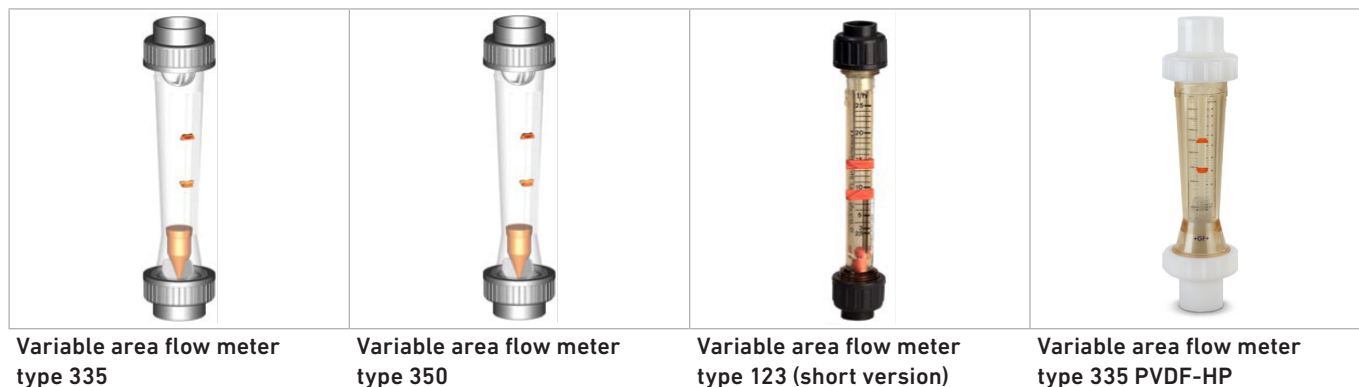

### Product description

Variable area flow meters from GF Piping Systems are radially installed, dismountable meters for measuring the flow rate in industrial piping system constructions. The measuring principle is advanced and efficient. The measurement ranges, which are tailored to our customers' needs, and the range of materials available for the tubes and screwed fittings, allow the flow meters to be used for a wide range of applications and a great variety of media.

#### Function

If a medium flows upwards through the vertically mounted measuring tube at a sufficient flow velocity, the float is raised to the point at which a state of equilibrium sets in between the lifting force of the medium and the weight of the float. As the mean flow velocity is proportional to the quantity flowing through per unit of time, this state of equilibrium corresponds to the measurement of the current flow volume.

#### Applications

- Water treatment
- Chemical process industry
- Microelectronics
- Food industry
- Ship building
- Building services engineering

#### Benefits/features

- Easy and cost effective measurement principle
- No additional energy required for operation
- Easy reading of the measured value
- Available scale range from 50 l/h up to 60'000 l/h
- Printed double scale for water in percent and l/h
- Special scales for liquid and gaseous media can be attached
- Wide range of materials
- Break-proof and corrosion resistant
- Large dimensions with guiding rod (PVDF-coated)

#### Flow media

For liquid and gaseous media, [see online tool ChemRes PLUS](#).

## Technical data

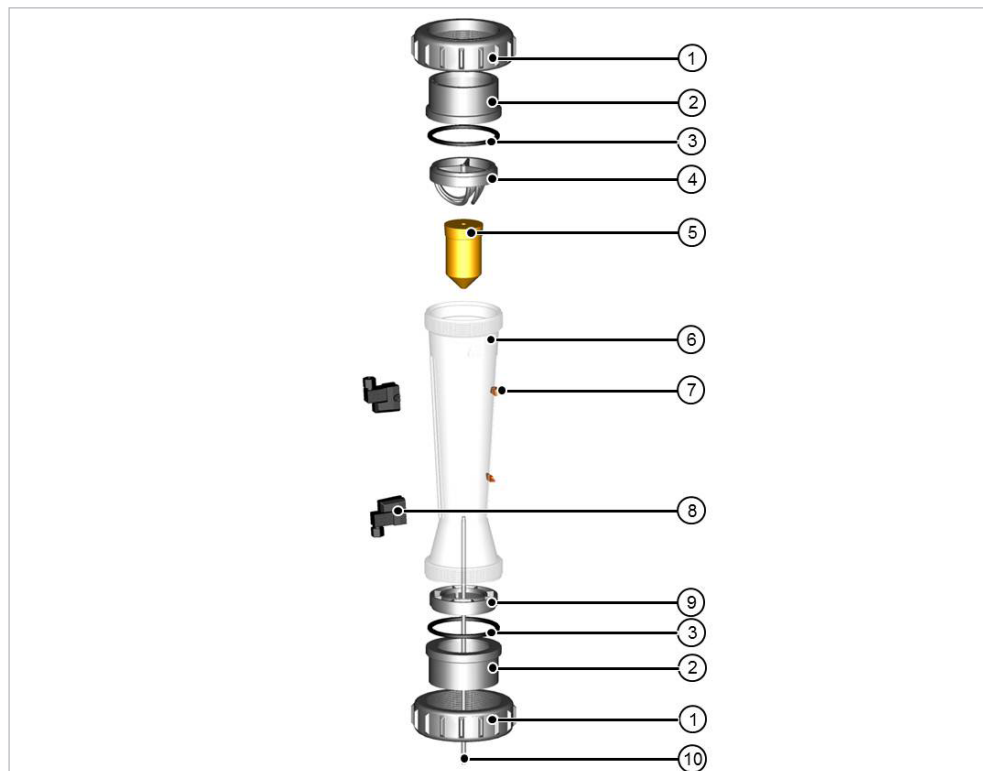

- ① Coupling nut
  - ② Threaded bush
  - ③ O-ring
  - ④ Top insert
  - ⑤ Float
  - ⑥ Measuring tube
  - ⑦ Flow value indicator
  - ⑧ Limit contact<sup>1</sup>
  - ⑨ Bottom insert
  - ⑩ Guiding rod<sup>2</sup>
- <sup>1</sup> Optional  
<sup>2</sup> Only for DN50 and DN65

Specification		
Dimensions	Type 335	d32/DN25 - d75/DN65, 1" - 2 1/2"
	Type 350	d32/DN25 - d75/DN65, 1" - 2 1/2"
	Type 123 (short version)	d16/DN10 - d32/DN25, 3/8" - 1"
	Special version	d32/DN25 - d75/DN65, 1" - 2 1/2"
Measuring tube materials	Type 335	PA, PSU, PVC-U transparent
	Type 350	PA, PSU, PVC-U transparent
	Type 123 (short version)	PVC-U transparent, PSU
	Special version	PSU-HP
Float materials	PVDF, PTFE*	
Gasket material	O-rings	EPDM, FKM
Pressure rating	PN10	
Scale ranges	Type 335	50 - 60'000 l/h
	Type 350	50 - 60'000 l/h
	Short version	2.5 - 1'000 l/h
	Special version	50 - 30'000 l/h
Connections	Type 335, 350, SK	PVC-U solvent cement sockets
	Special version	PVDF-HP fusion spigots
	Additional designs and materials (e.g. stainless steel) upon request	

\*special version type 123

## Pressure losses

Pressure loss of type 335/350		
Scale range (l/h)	Type	Pressure loss (mbar)
50 - 500	335 / 350	22.84
100 - 1000	335 / 350	22.84
150 - 1500	335 / 350	22.84
250 - 2500	335 / 350	22.84
200 - 2000	335 / 350	24.99
300 - 3000	335 / 350	24.99
600 - 6000	335 / 350	24.99
1000 - 10000	335 / 350	24.99
1500 - 15000	335 / 350	28.23
2000 - 20000	335 / 350	45.67
3000 - 30000	335 / 350	45.67
8000 - 60000	335 / 350	47.24

Pressure loss of type 123 (short version)		
Scale range (l/h)	Type	Pressure loss (mbar)
2.5 - 25	SK 50/500	4.31
5 - 50	SK 51/510	4.31
10 - 100	SK 52/520	4.31
8 - 80	SK 60/600	8.14
15 - 150	SK 61/610	8.14
20 - 200	SK 62/620	8.14
15 - 150	SK 70/700	4.51
30 - 300	SK 71/710	4.51
50 - 500	SK 72/720	4.51
100 - 1000	SK 73/730	4.51

## Dimensions

### Type 335

Scale range (l/h)	Type	D (mm)	DN (mm)	L (mm)	L1 (mm)	L2 (mm)	G (Inch)
50 - 500	335	58	25	385	341	335	1 ½
100 - 1000	335	58	25	385	341	335	1 ½
150 - 1500	335	72	32	393	341	335	2
250 - 2500	335	72	32	393	341	335	2
200 - 2000	335	83	40	403	341	335	2 ¼
300 - 3000	335	83	40	403	341	335	2 ¼
600 - 6000	335	83	40	403	341	335	2 ¼
600 - 6000	335	101	50	417	341	335	2 ¾
1000 - 10000	335	101	50	417	341	335	2 ¾
1500 - 15000	335	101	50	417	341	335	2 ¾
2000 - 20000	335	135	65	429	341	335	3 ½
3000 - 30000	335	135	65	429	341	335	3 ½
8000 - 60000	335	135	65	429	341	335	3 ½

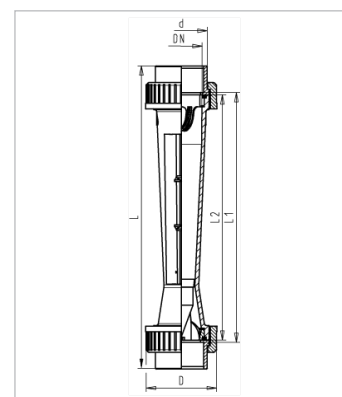

### Special version Type 335 PVDF-HP

Scale range (l/h)	Type	D (mm)	DN (mm)	L (mm)	L2 (mm)	G (Zoll)
100 - 1000	335	60	25	453	335	1 ½
300 - 3000	335	83	40	466	335	2 ¼
600 - 6000	335	83	40	466	335	2 ¼
1000 - 10000	335	101	50	472	335	2 ¾
1500 - 15000	335	101	50	472	335	2 ¾
2000 - 20000	335	122	65	495	335	3 ½
3000 - 30000	335	122	65	495	335	3 ½

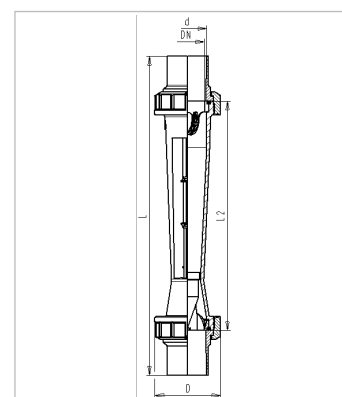

### Type 350

Scale range (l/h)	Type	D (mm)	DN (mm)	L (mm)	L1 (mm)	L2 (mm)	G (Inch)
50 - 500	350	58	25	400	356	350	1 ½
100 - 1000	350	58	25	400	356	350	1 ½
150 - 1500	350	72	32	408	356	350	2
250 - 2500	350	72	32	408	356	350	2
200 - 2000	350	83	40	418	356	350	2 ¼
300 - 3000	350	83	40	418	356	350	2 ¼
600 - 6000	350	83	40	418	356	350	2 ¼
600 - 6000	350	101	50	432	356	350	2 ¾
1000 - 10000	350	101	50	432	356	350	2 ¾
1500 - 15000	350	101	50	432	356	350	2 ¾
2000 - 20000	350	135	65	444	356	350	3 ½
3000 - 30000	350	135	65	444	356	350	3 ½
8000 - 60000	350	135	65	444	356	350	3 ½

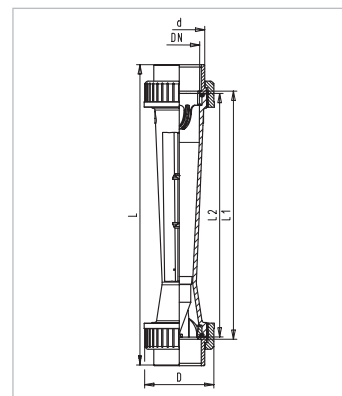

### Type 123 (short version)

Scale range (l/h)	Type	D (mm)	DN (mm)	L (mm)	L1 (mm)	L2 (mm)	G (Inch)
2.5 - 25	SK 50/500	35	10	199	171	165	¾
5 - 50	SK 51/510	35	10	199	171	165	¾
10 - 100	SK 52/520	35	10	199	171	165	¾
8 - 80	SK 60/600	43	15	223	191	185	1
15 - 150	SK 61/610	43	15	223	191	185	1
20 - 200	SK 62/620	43	15	223	191	185	1
15 - 150	SK 70/700	60	25	250	206	200	1 ½
30 - 300	SK 71/710	60	25	250	206	200	1 ½
50 - 500	SK 72/720	60	25	250	206	200	1 ½
100 - 1000	SK 73/730	60	25	250	206	200	1 ½

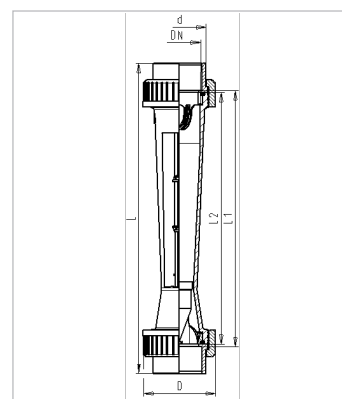

### Special version Type 123 PVDF-HP

Scale range (l/h)	Type	D (mm)	DN (mm)	L (mm)	L2 (mm)	G (Inch)
68 - 204	SK 70	60	25	318	200	1 ½
90 - 295	SK 71	60	25	318	200	1 ½
136 - 795	SK 73	60	25	318	200	1 ½

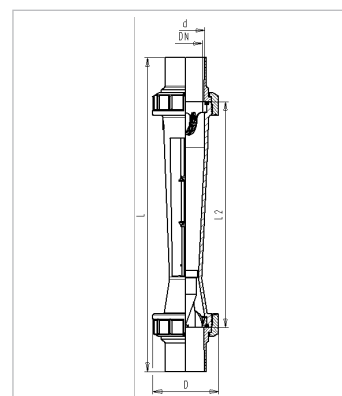

# Measuring accuracy

## Type 335/350

Measuring accuracy according to VDI/VDE 3513, error limit value G = 5%, range of linearity q<sub>6</sub> = 50%, this means up to max. +/- 5% of the final value.

Flow rate in %	10	20	30	40	50	60	70	80	90	100
Total measurement error % of measured value	13.0	8.0	6.3	5.5	5.0	5.0	5.0	5.0	5.0	5.0
Total measurement error % of full scale value	1.3	1.6	1.9	2.2	2.5	3.0	3.5	4.0	4.5	5.0

### Measuring accuracy

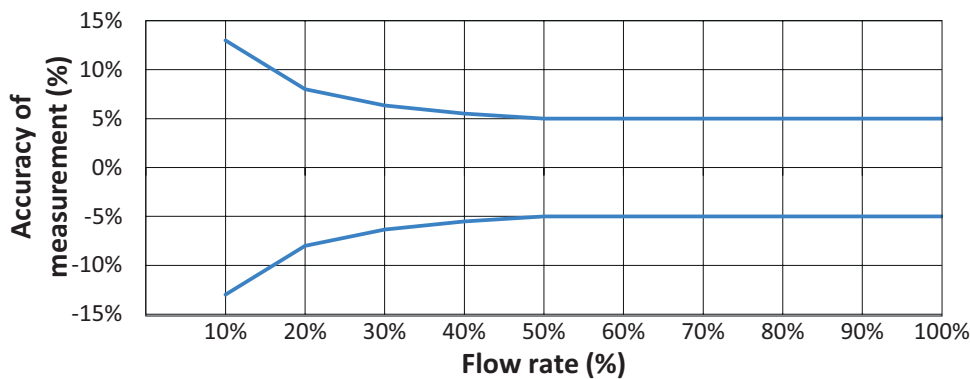

## VAFM Type 123 (short version)

Accuracy class 4 according VDE/DIN 3513 page 2.

Flow rate in %	10	20	30	40	50	60	70	80	90	100
Total measurement error % of measured value	13.0	8.0	6.3	5.5	5.0	4.7	4.4	4.3	4.1	4.0
Total measurement error % of full scale value	1.3	1.6	1.9	2.2	2.5	2.9	3.1	3.4	3.7	4.0

### Measuring accuracy

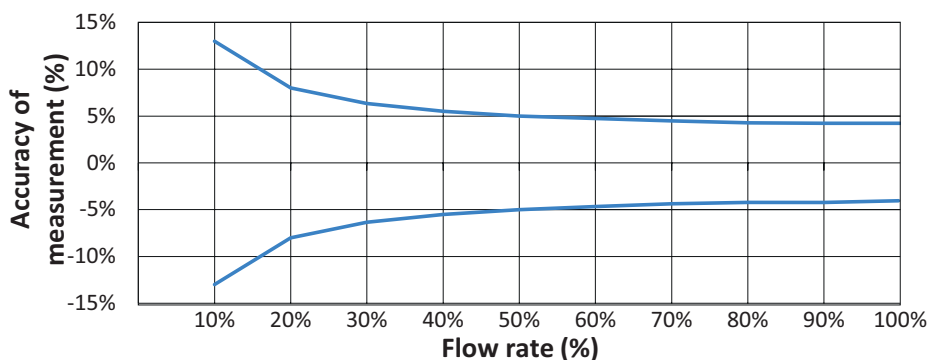

## Temperature range

To determine the maximum internal pressure at high temperatures, we refer you to our material-related pressure-temperature diagrams for reference values.

Measuring tube	Union	Max. temperature at 1 bar
PVC-U	PVC-U	0 – 60°C
PA	PVC-U	0 – 60°C
PSU	PVC-U	0 – 60°C
PSU	PVDF	0 – 90°C

### Pressure-Temperature diagram

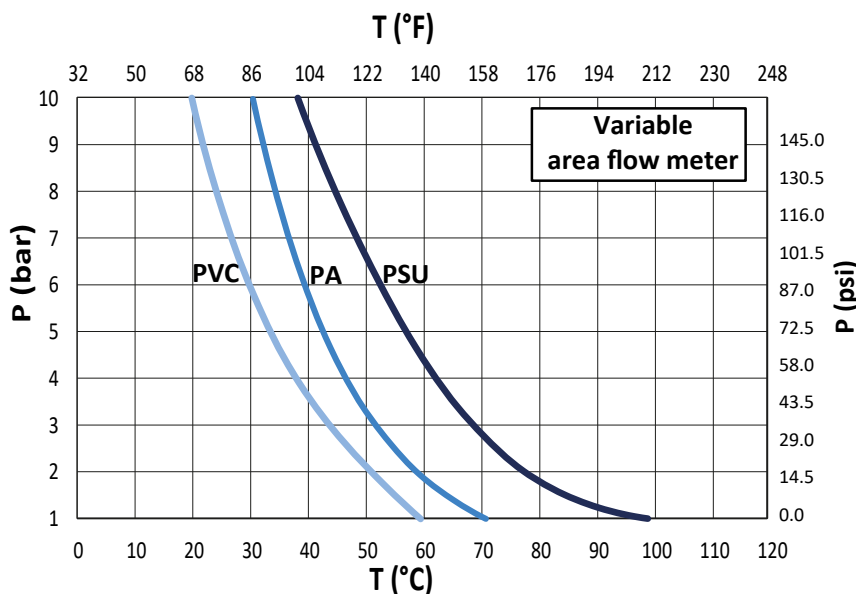

## Adjustment factors

### Temperature correction table for gases

	Calibrating temperature (°C)									
	0	10	20	30	40	50	60	70	80	
Operating temperature (°C)	0	1	1,018	1,035	1,052	1,07	1,088	1,103	1,12	1,135
	10	0.983	1	1,018	1,035	1,051	1,068	1,084	1.1	1,116
	20	0.965	0.983	1	1,015	1,032	1,05	1,065	1,08	1,096
	30	0.948	0.966	0.983	1	1,015	1,031	1,047	1,062	1,08
	40	0.933	0.95	0.967	0.984	1	1,015	1,031	1,046	1,061
	50	0.92	0.936	0.953	0.968	0.984	1	1,015	1,03	1,045
	60	0.905	0.922	0.938	0.955	0.968	0.985	1	1,015	1,03
	70	0.892	0.907	0.924	0.94	0.955	0.97	0.985	1	1,014
	80	0.88	0.895	0.912	0.927	0.943	0.965	0.971	0.987	1

**√ Example**

Calibrating temperature is 20 °C and operating temperature is 70 °C. Take the factor 0.924 from the calibrating temperature column for 20 °C and the operating temperature row for 70 °C. The values shown by the flow meter have to be multiplied by this factor in order to calculate the actual flow volume at an operating temperature of 70 °C. Use the following formula to get the factor:

$$\sqrt{\frac{T_c + 237}{T_o + 237}} = \sqrt{\frac{20 + 237}{70 + 237}} = 0.924$$

T<sub>c</sub> Calibrating temperature  
T<sub>o</sub> Operating temperature

**⚠ Note**

Operating temperature > calibrating temperature: factor < 1  
Operating temperature < calibrating temperature: factor > 1

**Density correction table for gases**

Gases for calibration							
Operating gases	P(kg/Nm <sup>3</sup> )	Air	Oxygen	Nitrogen	Ammonia	Acetylene	Chlorine
Air	1,293	1,000	1,050	0.983	0.772	0.953	1,580
Oxygen	1,429	0.953	1,000	0.935	0.735	0.906	1,500
Nitrogen	1,251	1,017	1,069	1,000	0.786	0.968	1,604
Ammonia	0.771	1,295	1,360	1,272	1,000	1,232	2,040
Acetylene	1,171	1,050	1,105	1,033	0.812	1,000	1,660
Chlorine	3,220	0.633	0.665	0.623	0.490	0.603	1,000
Hydrogen	0.089	3,810	4,010	3,750	2,940	0.630	6,020
Carbon dioxide	1,977	0.080	0.850	0.796	0.625	0.770	1,275
Sulphur dioxide	2,926	0.668	0.698	0.654	0.514	0.633	1,050
Coal gas	0.550	1,532	1,610	1,506	1,185	1,460	2,420
Propane	2,020	0.800	0.841	0.786	0.618	0.762	1,262

The data in the table serve to correct the values displayed by the flow meter for gaseous media when the operating temperature deviates from the weight of 1.293 kg/Nm<sup>3</sup> (air) used for the calibration.

**√ Example**

Specific weight at the time of calibration is 1.293 kg/Nm<sup>3</sup> (air). The medium hydrogen with its specific weight of 0.089 kg/Nm<sup>3</sup> is to be measured. From the calibrating gases/air column, in row seven for operating gases/hydrogen, you obtain the factor 3.81. The values shown by the flow meter have to be multiplied by this factor in order to determine actual flow volume at a specific weight of 0.089 kg/Nm<sup>3</sup>.

**⚠ Note**

Operating gas density > calibration gas density factor < 1  
Operating gas density < calibration gas density factory > 1

Density correction table for liquids

Density of liquid (kg/l) float material PVDF	
Density of operating liquid (kg/l)	
	0.5 0.6 0.7 0.8 0.9 1 1.1 1.2
0.5	1 1,105 1.2 1.29 1.38 1,464 1,545 1.63
0.6	0.903 1 1,084 1,168 1,248 1.32 1,397 1,475
0.7	0.834 0.923 1 1,078 1.15 1.22 1.29 1.36
0.8	0.775 0.856 0.928 1 1,066 1,133 1,196 1,262
0.9	0.724 0.802 0.87 0.937 1 1.06 1.12 1.18
1.0	0.683 0.755 0.818 0.883 0.94 1 1,055 1,114
1.1	0.645 0.715 0.771 0.836 0.892 0.946 1 1,055
1.2	0.613 0.678 0.735 0.793 0.845 0.896 0.947 1
1.3	0.585 0.648 0.7 0.755 0.807 0.857 0.903 0.955
1.4	0.56 0.62 0.671 0.723 0.773 0.82 0.865 0.913
1.5	0.537 0.595 0.645 0.695 0.743 0.787 0.832 0.877
1.6	0.515 0.57 0.618 0.665 0.712 0.755 0.798 0.84
1.7	0.496 0.548 0.595 0.641 0.685 0.726 0.767 0.81
1.8	0.478 0.538 0.574 0.617 0.66 0.7 0.74 0.78
1.9	0.462 0.511 0.555 0.597 0.638 0.676 0.715 0.755
2.0	0.446 0.495 0.536 0.578 0.617 0.654 0.691 0.73

Density of liquid (kg/l) float material PVDF	
Density of operating liquid (kg/l)	
	1.3 1.4 1.5 1.6 1.7 1.8 1.9 2
0.5	1.71 1,785 1.86 0.94 2.02 2.09 2.16 2.24
0.6	1,545 1,615 1.68 0.754 1.82 1.89 1.95 2.02
0.7	1,425 1.49 1.55 1,615 1.68 1,745 18 1,865
0.8	1,325 1.38 1.43 1.5 1.56 1.62 1.67 1.73
0.9	1.24 1,295 1.35 1,405 1.46 1,515 1.57 1.62
1.0	1.17 1.22 1.27 1,325 1,375 1.43 1.48 1.53
1.1	1,106 1,155 1.2 1,255 1.3 1.35 1.4 1.45
1.2	1.05 1,095 1.14 1.19 1,235 1.28 1.33 1.37
1.3	1 1,044 1,088 1,134 1,176 1.22 1,264 1,305
1.4	0.958 1 1,042 1,085 1.13 1.17 1.21 1.25
1.5	0.92 0.96 1 1,042 1,084 1,125 1.16 1,205
1.6	0.882 0.92 0.958 1 1.04 1.08 1.11 1.15
1.7	0.848 0.886 0.923 0.961 1 1,038 1,072 1.11
1.8	0.817 0.853 0.888 0.926 0.962 1 1,032 1.07
1.9	0.79 0.826 0.858 0.897 0.93 0.968 1 1,034
2.0	0.798 0.798 0.83 0.867 0.9 0.935 0.965 1

The data in the table serve to correct the values displayed by the flow meter for gaseous media when the operating temperature deviates from the specific weight of 1.0 kg/l (water) used for the calibration.

**Example**  
 Specific weight at calibration 1.0 kg/l (water). The liquid media with a specific weight of 0.9 kg/l is to be measured. If you have a calibrating solution of 1.0 kg/l, you can find the factor 1.06 in column 5 under operating liquid density 0.9 kg/l. The values shown by the flow meter have to be multiplied by this factor in order to calculate the actual flow volume at a specific weight of 0.9 kg/l.

**Note**  
 New density is larger: factor < 1  
 New density is lower: factor > 1



# Accessories

## Limit contacts Type GK10/11

Variable area flow meters from GF Piping Systems are equipped with two dovetail guides. For external electrical monitoring, these can be used for fitting magnetically actuated limit contacts.

### Function of the limit contact (GK)

The limit contact serves to monitor externally the limited flow values and can be adjusted to any flow value on the corresponding scale. The magnet built into the float closes or opens a reed contact in the limit contact. This is a bistable switching function, the switching status remains when the float is taken from the contact.

Note: When subsequently mounting limit contacts, mind that you have to replace the standard float with a magnetic float.

The limit contacts GK10/GK11 are only suitable for the VAFM Type 335/350 as well as the short version of the existing range. The same contact type can not be used for monitoring both the min. and max. levels (GK10 min./GK11 max.).

Even a brief overshoot is not permitted. This is uncontrollable with inductive or capacitive peaks, e.g. with solenoid valves. Therefore it is recommended to use a limit valve switch or a contact protection relay.

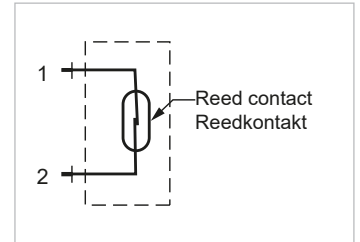

Technical data	
Connection	Standard connector DIN 40050
Contact fitted	Dry reed contact
Protection rating	IP 65
Max. nominal voltage	250 V
Max. switching rating	10W / 10VA
Max. Peak-switching current	0.5 A
Continuous rating	0.2A
Contact resistance	<150 mOhm
Leakage resistance	>10 <sup>11</sup> Ohm
Ambient temperature	0°C to +55°C
Protection rating	IP65

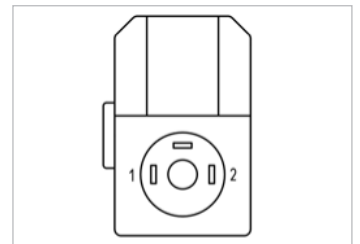

## Contact function

Position of float in relation to limit contacts

	Top	Bottom
Max. contact (GK11)	Closed	Open
Min. contact (GK10)	Open	Closed

The contacts remain in these positions, even if the float leaves the corresponding contact. When the float moves back to the desired position, the corresponding contact is deactivated.

## Assembly

1. Replace the float with a magnetic float
2. Position the limit contact on the dovetail guide of the FAVM
3. Tighten fastening screw

### 4-20mA measured value sensor type GK15

The measured value sensor type GK15 uses a special, newly developed electronic system with a microprocessor and sensors. The GK15 provides an output signal of 4-20mA, according to the level setting of the magnetic float in the flow meter. This signal could be used by a PLC, for example, to control processes or to show the precise flow rate on an external display. For use with inductive loads, use a relay to protect the contacts.

**⚠** As the resolution of the various scales differs, the sensor is programmed individually at the factory for each measurement range. Therefore, please identify your required measurement range when you place the order.

Technical data	
Supply voltage	12-24 VDC (+ - 10%)
Current consumption	<50 mA
Load resistance	Min. 0 max. 500 Ω
Current output	4-20mA (3 wire)
Protection rating	IP65
Ambient temperature	0 °C to 50 °C
Process Connection	Plug DIN 43650
Measuring accuracy	<1%

### Dimensions

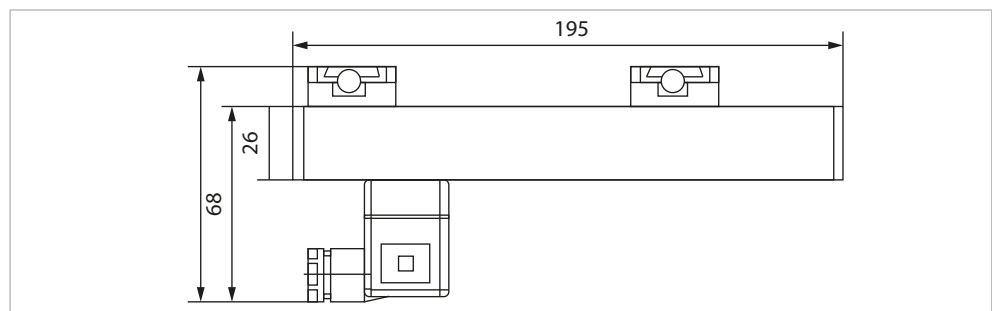

### GK15 function elements

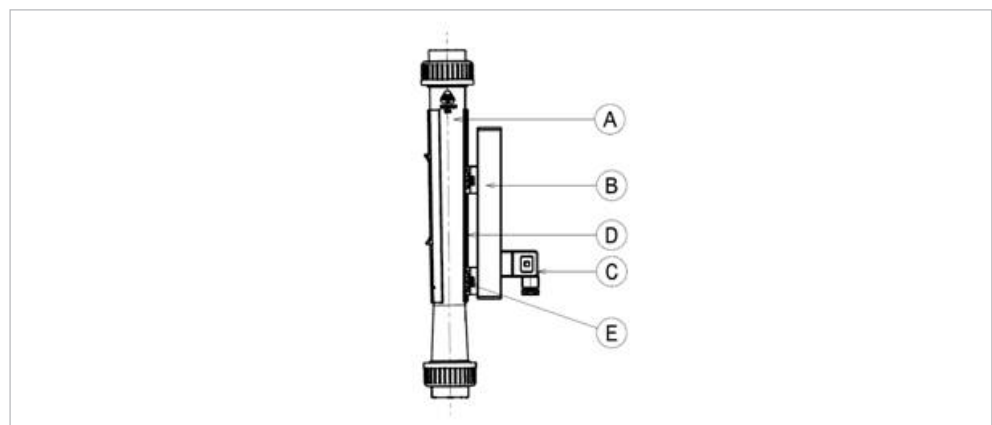

- A Flow Meter Type 335/350 with magnetic float
- B Sensor GK15
- C Cable plug
- D Dovetail guide
- E Clamping screws, for fastening and adjusting sensor

### Assembly

1. Position the sensor on the dovetail guide of the area flow meter
2. Adjust the notch on the GK15 sensor to the 50% mark on the scale
3. Tighten the clamping screws
4. Take off the plug and wire it according to the displayed electrical connection

### Electrical connection

#### Wiring diagram measured value sensor

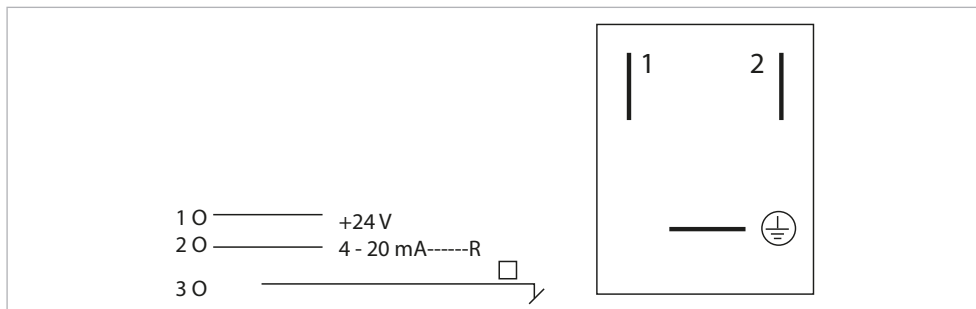

- Pin1 Operating voltage  
12 – 24 V
- Pin2 Output signal 4-20mA
- Pin3 0 V
- Pin4 Must not be used or wired. For programming only.
- Pin5 Must not be used or wired. For programming only.

#### Wiring diagram measured value sensor plug

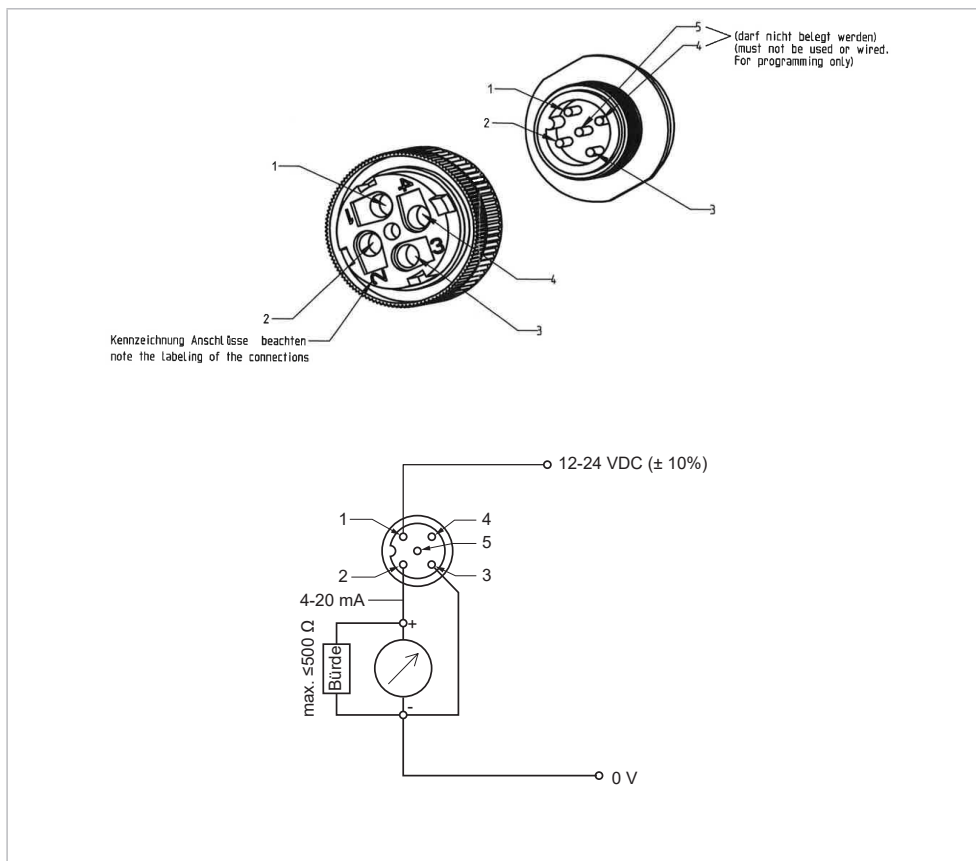

For further information on accessories, refer to the online product catalogue at [www.gfps.com](http://www.gfps.com)

The information and technical data (altogether "Data") herein are not binding, unless explicitly confirmed in writing. The Data neither constitutes any expressed, implied or warranted characteristics, nor guaranteed properties or a guaranteed durability. All Data is subject to modification. The General Terms and Conditions of Sale of Georg Fischer Piping Systems apply.

10/2021-A

© Georg Fischer Piping Systems Ltd, 8201 Schaffhausen/Switzerland  
 Tel. +41 52 631 11 11 • [www.gfps.com](http://www.gfps.com) • E-Mail: [info.ps@georgfischer.com](mailto:info.ps@georgfischer.com)