

# Battery Capacity Testers

24–250 Vdc, 0–300 Amp Series of Constant Current Load Banks

The only way to know if your stationary batteries will perform to specification is to test them regularly.

NERC standard PRC-005-2 requires that vented lead acid and nickel cadmium (NiCd) systems be discharge tested every six (6) years and valve regulated lead acid (VRLA) batteries every three (3) years. IEEE recommends load testing stationary flooded/vented lead acid and NiCd stationary batteries every five (5) years and VRLA batteries every 12–18 months.

The SBS constant current load banks are an affordable way to perform easy and accurate IEEE450 (vented lead acid), IEEE1106 (NiCd) and IEEE1188 (VRLA) load tests.

These units are quick and easy to set up. They display the voltage, current and Ah removed from the string during the test. Since this is a constant current load bank, the user also does not have to adjust the current during the test.

These load banks come standard with multiple adjustable stop points and built-in protection to ensure that the batteries are never damaged due to over-discharge.

## Features

- Many unit options with wide voltage and current range
- Automatically discharges batteries unmanned without danger of over-discharging
- Continuously holds the current set throughout the test
- LCD screen displays real time voltage, discharge current and capacity/Ah removed
- Test parameters are adjustable during test without stopping test
- 3 adjustable stop points for built-in protection
  - End system voltage
  - Discharge time
  - Discharge capacity (Ah)
- Units can be slaved with the SBS-8400 and/or other load banks to increase amp draw

## Built-in Protection

- Audible alarm
- Warning on LCD screen
- High temperature shutdown
- High voltage shutdown
- Overload protection

DC LOAD BANKS

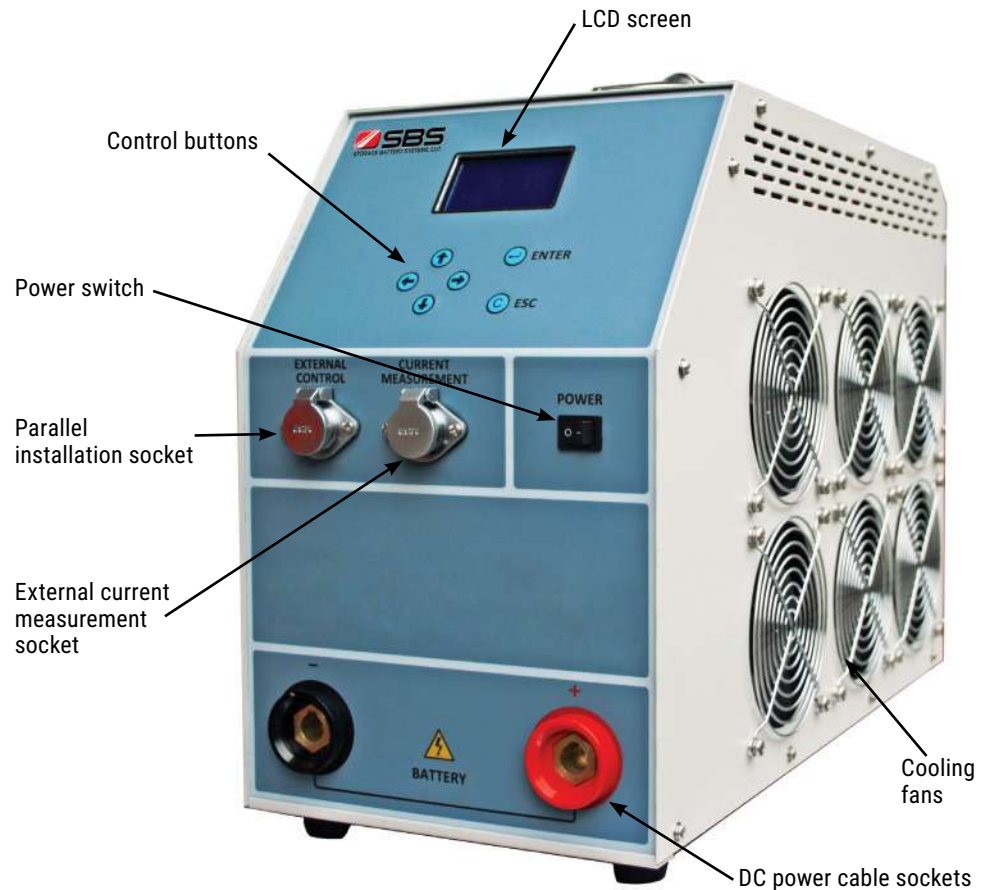

SBS-4830S



SBS-1110S



**Includes**

- Main unit
- Instruction manual
- 9 ft. DC cables
- Carrying case with wheels

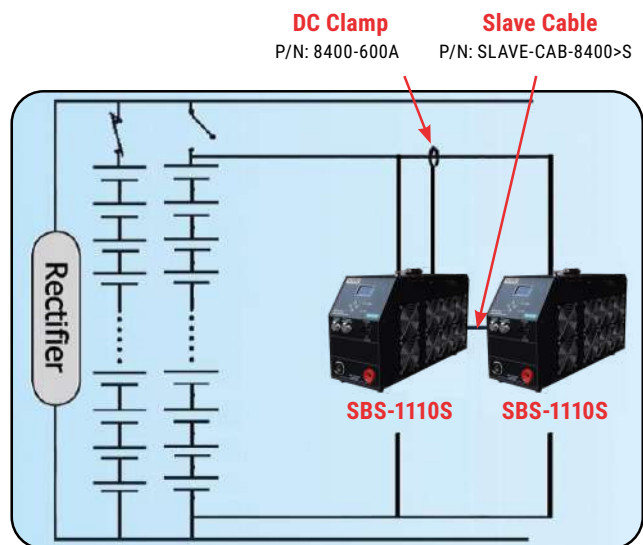

With the optional P/N 8400-600A DC clamp the user can parallel additional load banks of the same voltage range to increase discharge current.

**Ordering Information**

Part No.	Description
SBS-4830S	24 Vdc 0–150 Amp / 48 Vdc 0–300 Amp Constant Current Load Bank
SBS-1110S	125 Vdc 0–100 Amp Constant Current Load Bank
SBS-1230S	125 Vdc 0–300 Amp Constant Current Load Bank
SBS-2206S	250 Vdc 0–60 Amp Constant Current Load Bank
SBS-2415S	250 Vdc 0–150 Amp Constant Current Load Bank

**Accessory Ordering Information**

Part No.	Description
8400-600A	600 DC Current Clamp
SLAVE-CAB-8400>S	Paralleling Cable, S-Series to S-Series/SBS-8400/SBS-4815
SLAVE-CAB-8400>(2)S	Paralleling Cable, S-Series to (2) S-Series/SBS-8400/SBS-4815
BCT110/220-1000	750 Watt Voltage Transformer 110/220 Vac 50/60 Hz

**Technical Data**

Display	LCD (128 x 64 pixels)
Input	During discharge: real time voltage / current / test time / capacity discharged (Ah) User can set: end system voltage / test time / capacity discharged (Ah)
Test Type	Unit holds the set current throughout the test
Protection	Overheat / Overload / Over voltage protection with audible alarm and screen warning
Power Supply	SBS-4830S uses DC power supply (from tested battery) 125 and 250 Vdc units use AC power supply (110 Vac 60 Hz)
DC Cables	Included, 9 ft. long

**Specifications**

Part No.	DC Voltage Range	DC Current Range (Amps)	Dimensions L x W x H (in.)	Weight (lb.)
SBS-4830S	20–40 Vdc 40–60 Vdc	0–150 A 0–300 A	26 x 9 x 16	40
SBS-1110S	90–150 Vdc	0–100 A	25 x 9 x 15	44
SBS-1230S	90–150 Vdc	0–300 A	36 x 9 x 25	110
SBS-2206S	190–265 Vdc	0–60 A	26 x 9 x 16	40
SBS-2415S	196–300 Vdc	0–150 A	36 x 9 x 25	110